

DISPLAY REFRIGERATOR

Model: 1RXNGD

Natural Refrigerant R-290 Model

1-Section Extra-Wide Display Reach-In Refrigerator with Hinged Glass Door

1RXNGD - Stainless steel front, aluminum end panels and interior

1RXNSAGD - Stainless steel exterior, aluminum interior

1RXNSSGD - Stainless steel exterior and interior



Options and Accessories

(upcharge and lead times may apply)

Stainless steel case back	Pan slide assemblies
Additional epoxy coated steel shelves	Wine rack
Chrome or stainless steel shelves	Adjustable legs
Shallow depth (consult factory)	Solid door (consult factory)
Rehinging of door (consult factory)	Special electrical req. (consult factory)
Half doors	Pass-thru (consult factory)

Consult factory for other model configurations, options and accessories.

Continental[®]
Refrigerator

Toll-Free: 800-523-7138
Phone: 215-244-1400
Fax: 215-244-9579

539 Dunksferry Road
Bensalem, PA 19020
www.continentalrefrigerator.com

Project Name:

Model Specified:

Location:

Item No:

Quantity:

AIA #:

SIS #:

Standard Model Features

REFRIGERATION SYSTEM

Self contained, performance rated refrigeration system

Natural, environmentally safe, high efficiency R-290 refrigerant¹

Automatic, electric condensate evaporator

Expansion valve system

CABINET ARCHITECTURE

3" non-CFC polyurethane foam insulation

Triple-pane, tempered hinged glass door

Chrome plated handle

Cam action, lift-off hinges

Self-closing door

Magnetic snap in door gasket

Cylinder lock in door in door

Heavy duty, epoxy coated steel shelves

Heavy duty pilaster strips

5" casters

MODEL FEATURES

LED interior lighting

Off cycle defrost

Electronic controller with digital display & hi-low alarm

¹ R-290 refrigerant meets all federal and state regulatory requirements.

APPROVAL:

Model Specifications

DIMENSIONAL DATA

Net Capacity (cubic feet)	30 (850 cu l)
Width, Overall (inches)	36 1/4 (921 mm)
Depth, Overall (inches) (including handle)	35 3/8 (899 mm)
Depth (inches) (less door)	32 (813 mm)
Depth (inches) (door open 90°)	66 (1676 mm)
Clear Door Width (inches)	29 5/8 (752 mm)
Clear Door Height (inches)	58 5/8 (1489 mm)
Height, Overall (inches) (including 5" casters)	82 1/4 (2089 mm)
Number of Doors	1
Number of Shelves	4
Shelf Area (square feet)	24.4 (2.3 sq m)

REFRIGERANT DATA

Condensing Unit Size (H.P.)	1/3+
Capacity (BTU per hour)*	2560

ELECTRICAL DATA

Voltage (International)	115/60/1 (220/50/1)
Feed Wires (including ground)	3
Total Amps (International)	7.6 (5.3)
10 ft. Cord/Plug [attached] (International)	Yes (No)

SHIPPING DATA

Height - Crated (inches)	85 1/2 (2172 mm)
Width - Crated (inches)	42 (1067 mm)
Depth - Crated (inches)	42 (1067 mm)
Volume - Crated (cubic feet)	87 (2464 cu l)
Weight Std - Crated (pounds)	440 (200 kg)
Weight SS - Crated (pounds)	465 (211 kg)

* Rating @ +25°F evaporator, 90°F ambient
 Figures in parentheses reflect metric equivalents rounded to the nearest whole unit.



Equipped with one NEMA-5-15P Plug
 (varies by country)

Model Plan Views

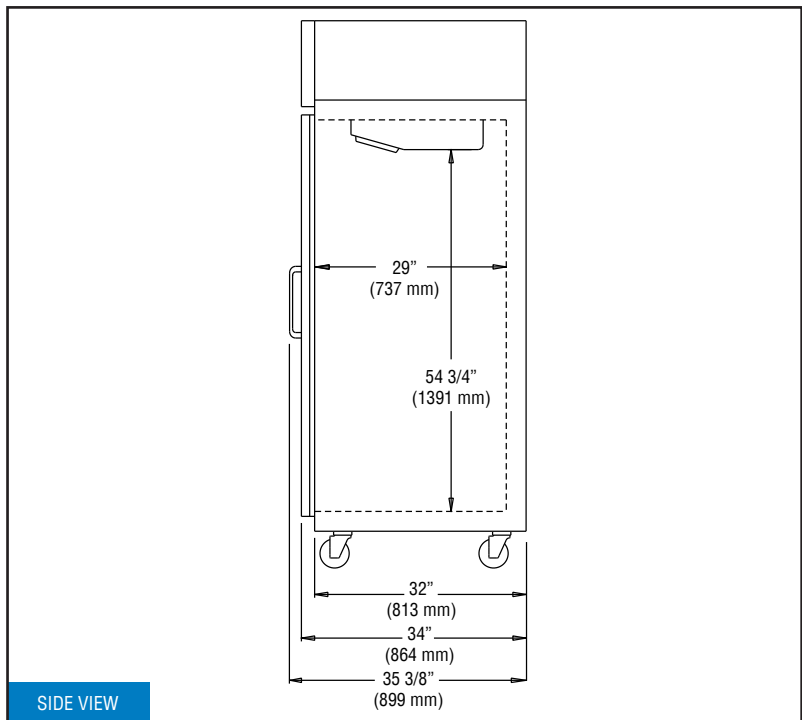
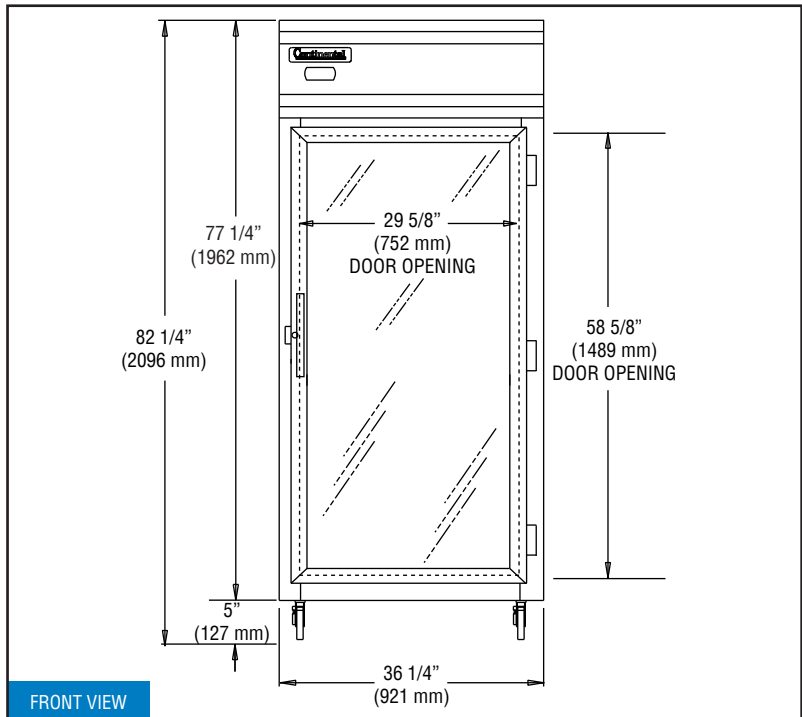

IMPORTANT NOTE: If the cabinet is located directly against a wall and/or under a low ceiling, a minimum clearance of 12" is required on top and 3" on sides and rear.



Toll-Free: 800-523-7138
 Phone: 215-244-1400
 Fax: 215-244-9579

539 Dunksferry Road
 Bensalem, PA 19020
www.continentalrefrigerator.com

Due to our continued efforts in developing innovative products, specifications subject to change without notice.

